



Black Diamond
BD Drill Drilling Services Australia

BD-H65

DTH surface drill rig for quarrying and mining
Hole diameter: 110-203 mm (4.3-8")



ABOUT US

Black Diamond Drilling Services Australia Pty Ltd



WA Headquarters: 52 Distinction Road, Wangara WA 6065

Tel: +61-08-6365-6550 **Email:** sales@bdrill.com.au **Web:** www.bdrill.com.au

Kalgoorlie Boulder: 2 Brooks Way, Kalgoorlie, WA, 6430

Tel: +61-08-9021-8478 **Email:** admin@gf@bdrill.com.au **Web:** www.bdrillgf.com.au

Black Diamond Drilling Tools Canada Inc.



Sudbury Headquarters: 1899 Lassalle Blvd, unit 6, Sudbury, On, Canada, P3A-2A3

Tel: +1-705-560-5888 **Email:** sales@bdrill.ca **Web:** www.bdrill.ca

Black Diamond Drilling Tools USA LLC.



New Hampshire Headquarters: 131 Daniel Webster Hwy, #426 Nashua, NH 03060

Tel: +1-978-319-8000 **Email:** sales@bdrill.us **Web:** www.bdrill.us

Black Diamond Drilling Mongolia LLC.



Ulan Bator Headquarters: No 206, Second Floor, Arig Center Jamyan Gun Street,
1st Khoroo, Sukhbaatar District, Ulaanbaatar, Mongolia

Tel: +976-99623888 **Email:** sales@bdrilling.mn

1000
EMPLOYEES



300,000
M² OF
FACTORY



ANNUAL PRODUCTION

DTH hammer: over 20,000 units

Maximum size for hammer: 609mm(24")

Drill bit: 250,000 pcs

Maximum size for drill bit: 1000mm(39-1/3")

30 days for production on any quantity



Black Diamond Drilling Services Australia Pty Ltd known as "BD DRILL" is a privately owned Australian Company which services the Mineral exploration, Mining, Water well and Geotechnical sectors of the drilling industry.

BD DRILL is a subsidiary of Changsha Heijingang Industrial Ltd. Co., the head office is located in Perth, Western Australia and supports regions in Australia and the overseas market.

BD DRILL has established a reputation for outstanding commitment to product quality, innovation and most importantly customer service.

Our extensive product range covers DTH equipment (conventional, reverse circulation, bits, strings and rigs), Top hammer and a comprehensive selection of various drilling products (diamond bit, drag bit, tricone bits, drilling grease and other consumables.)

USE OF LOCAL (AUSTRALIAN) CONTENT

Black Diamond Drilling Australia is a Western Australian fully owned and operated company. Our manufacturing facilities are based in Australia and China with a comprehensive Quality Control system in place. The R & D for Black Diamond Australia is completed right here by our highly experienced staff of which 80% are local Australians.

We utilise the service of a Local Queensland Indigenous company to be our distributor through the East Coast of Australia. Please see attached policies for local engagement, Quality, Indigenous Engagement, Australian Participation.

We use many local suppliers for training, logistics, I.T. etc.

Local Engagement

- Sponsorship and Advertising at Optus Stadium with the West Coast Eagles.
- Major Sponsor for the Annual Kalgoorlie Desert Race.
- Donations to several Cancer and Children's Charities.



Member of

- **ADIA** Australian Drilling Industrial Association



- The Australian Drilling Industry Association (ADIA) is the peak body representing the drilling industry nationally. It's membership is made up of individuals and companies committed to improving the skills, safety and overall professionalism of the drilling industry. It is the voice of its members, providing collective representation on matters that affect them and their businesses.

- **AMEC** Association of Mining and Exploration Companies



- AMEC is an industrial association representing over 375 member companies from all around Australia. Their members are explorers, emerging miners, producers and a wide range of businesses and service providers working in and for the mining industry. AMEC is a leading voice of Australia's mineral exploration and mining industry.

Perth, Australia



Sudbury, Canada



Kalgoorlie, Australia





CONTENTS

1 Appearance & layout	01
2 High configuration components	03
3 Technical specification	06
4 Company advantages	10

Appearance & layout

- Standard**
 - Atlas Two-stage screw compressor
 - CAT Electric injection diesel engine
 - Poclain Feed motor + Donghua chain +Aluminum alloy
 - Rexroth Travelling motor+ Floating track chassis
 - Parker high speed fan motor for dust collector
 - Waivoil control handle
 - Rexroth main pump&main valve
 - PLC&Pilot pressure control system
 - Drilling parameter measurement system
 - Φ114-6m RHS
 - FOPS/ROPS Cabin
 - 10 Construction lights
 - 2 Engine room maintenance lights
 - Maintenance-free air filter
 - Drill pipe thread lubrication system
 - DTH hammer lubrication system
- Optional**
 - Centralized lubrication system
 - Rear hydraulic leg
 - Water mist system (DYNASET)
 - Automatic fire extinguishing system (ANSUL)
 - Hydraulic oil manual filling pump
 - 45° drilling device
 - Φ140/Φ127/Φ102/Φ89 RHS
 - Auxiliary heating system (Engine intake, coolant, engine oil, fuel oil, hydraulic oil, air compressor oil, fuel and oil filter heating set, cab warm air, top glass defrosting)
 - Remote control system
 - Navigation and positioning system
 - Data management system

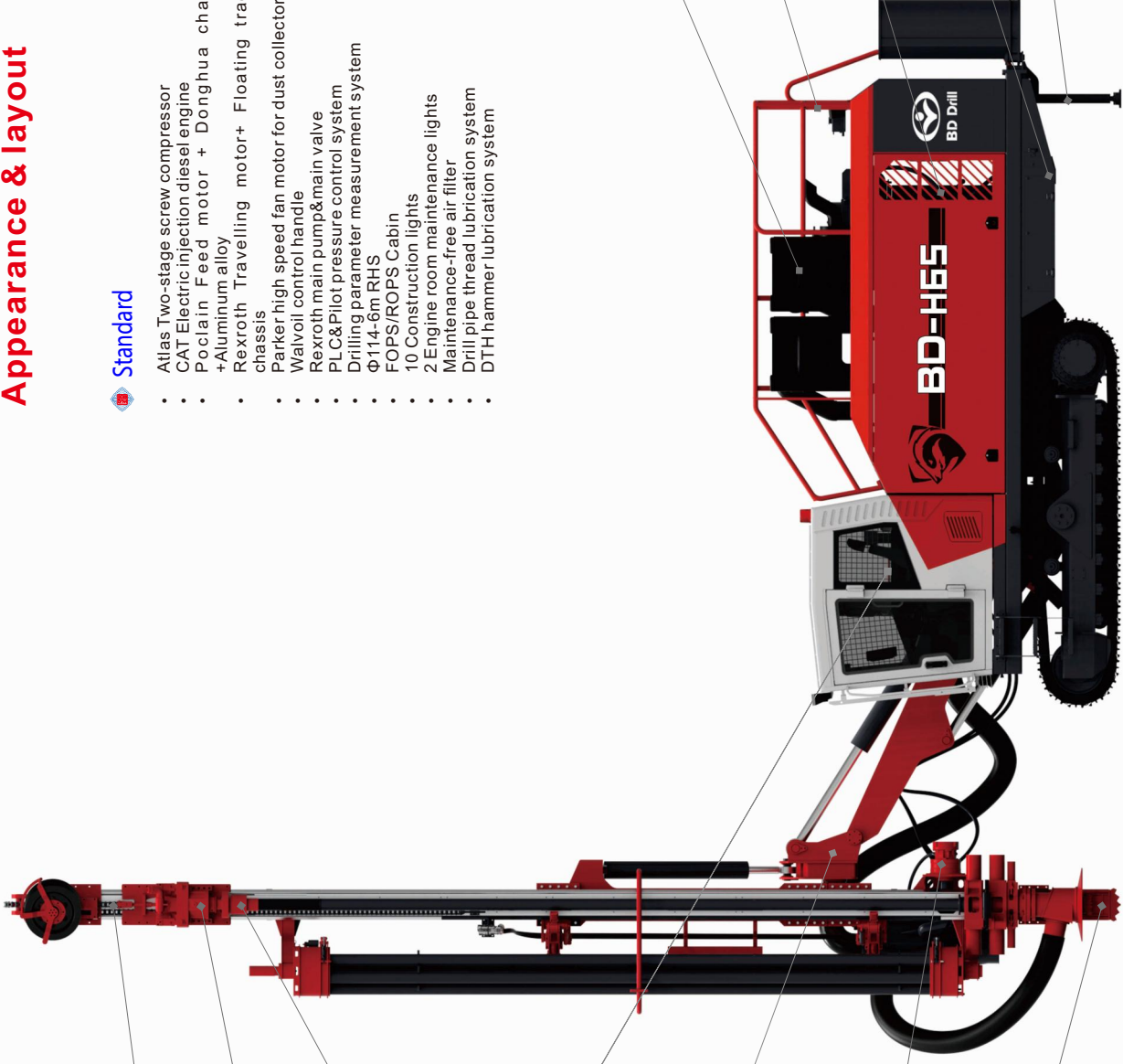

Aluminum profile beam
lighter weight, reduce vibration

High efficiency rotary head
High rotary speed, large torque, more reliability

Long life floating sub

Comfort carbin
Optimized layout, extended seat, safety approved

2 pivots side swing design
Extend scope of drilling

Underlying driving motor
Lower center of gravity, easier maintenance

Bits disassembly device
Easy to disassemble bits

Maintenance-free air filter
Extend period of replacement, adapt to harsh environment

Handrail
Keep maintenance personnel safety

Atlas Copco Air pressor
Powerful air source ,high reliability

Complete set of heating system
Enhance ability of low temperature start

Hydraulic Support leg
Enhance the stability on rough ground

High Configuration Components

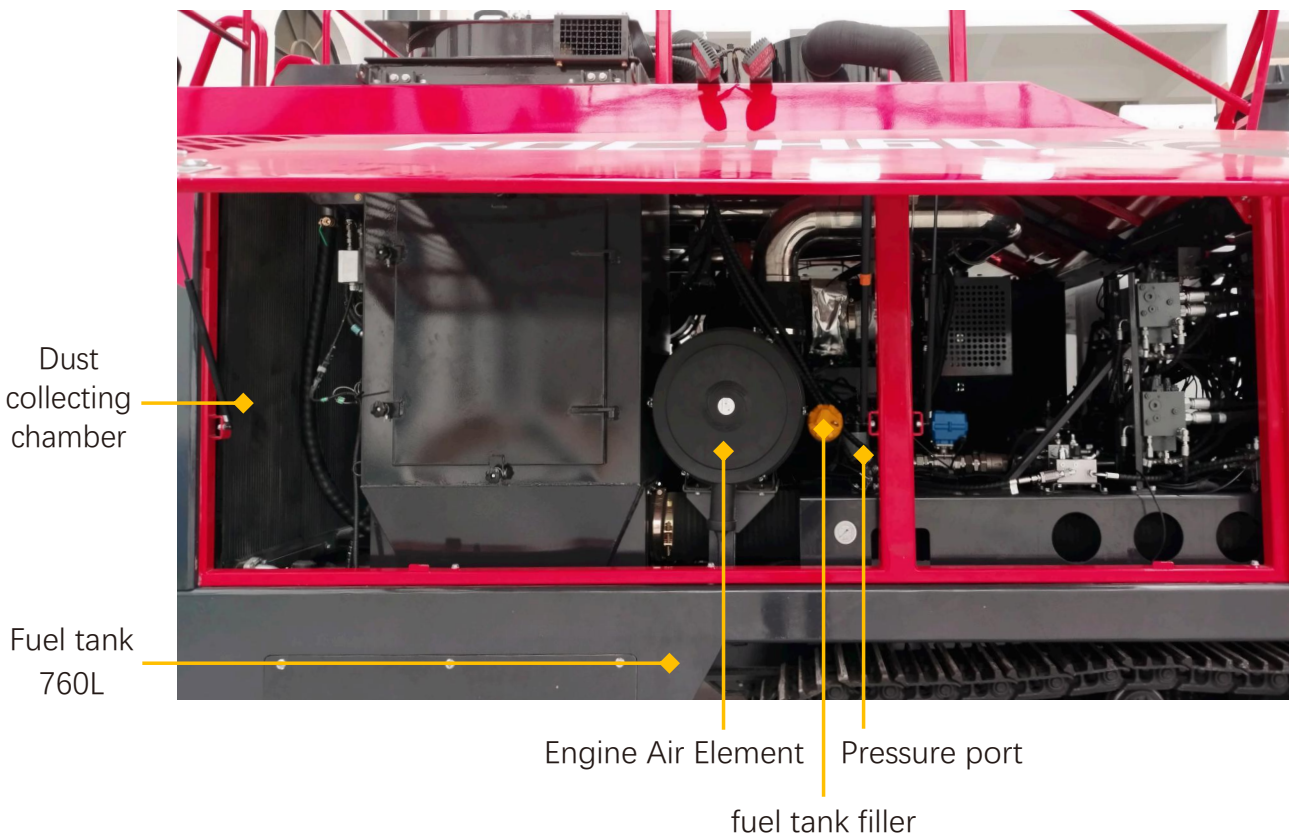
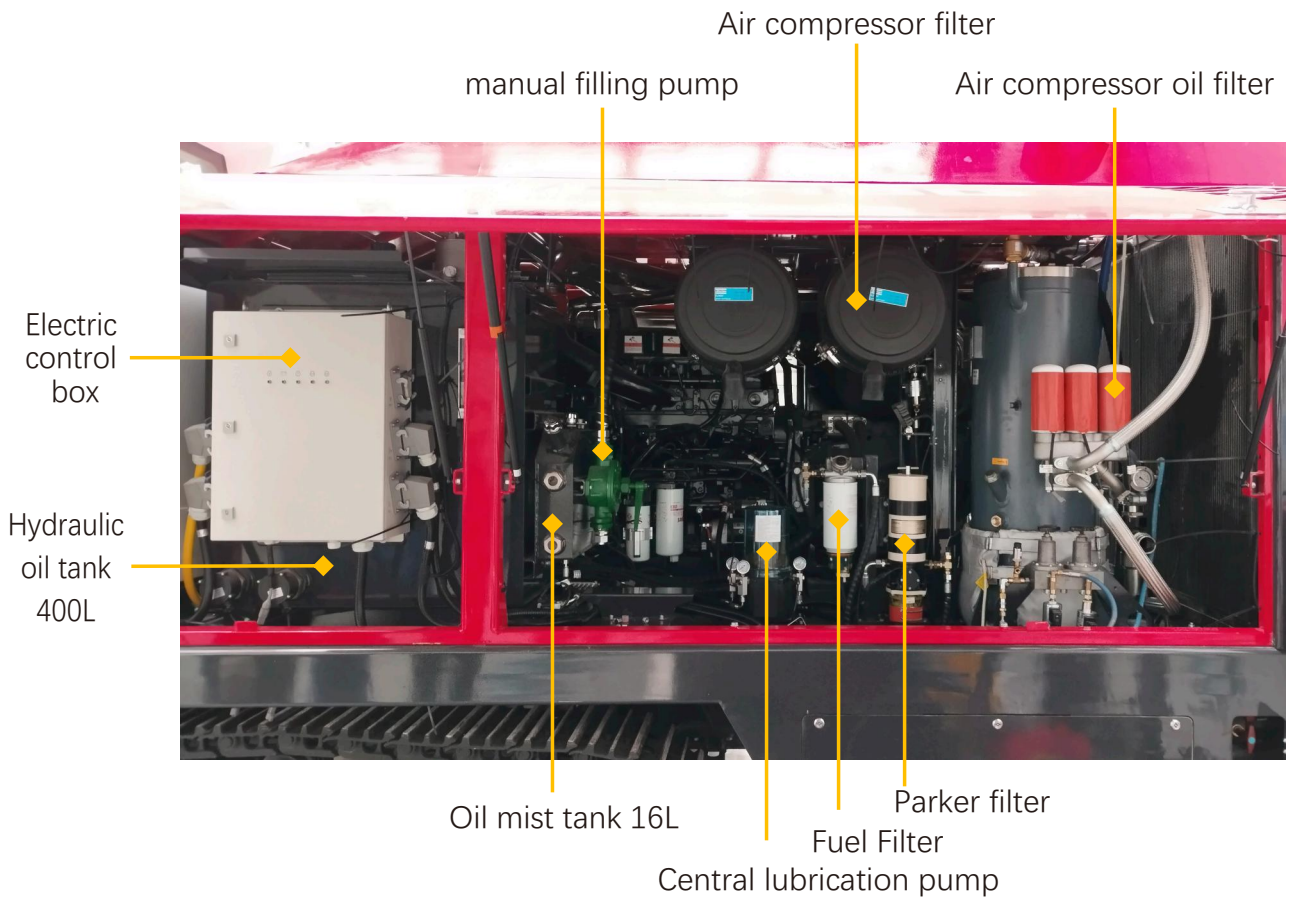



Powerful heating system

TYPE	Items	Parameter			
220V	Fuel tank heater	2kW/220V			
	Hydraulic oil heater	2×2kW/220V			
	Oil separator heater	1kW/220V			
	Engine oil heating	140W/220V			
	Battery heating pack	4×155W/220V			
24V	Oil suction heating system	130W/24V			
	Fuel filter heater	2×100W/24V			
	Oil-water separator heater	200W/24V			
	Oil filter heater	100W/24V			
	Air compressor oil filter heater	3×150W/24V			
	Air heater starting	2.45kW/24V			
Fuel	Engine coolant heater	180W			
	Cab heater	90W			

Excellent adaptability to mining environments

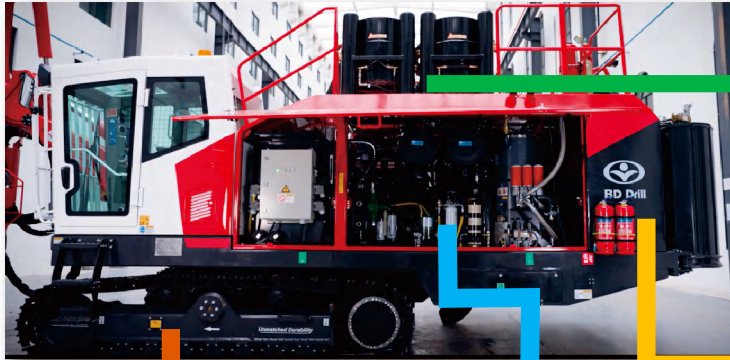

Additional maintenance-free desert filter is added, which enhances the cleanliness of air intake for the air compressor and engine, extends the replacement cycle of the filter element, and reduces the cost of consumables.



Adaptability to the rugged terrain of the mine site:

- ① 440mm ground clearance
- ② 176kN of traction force
- ③ $\pm 10^\circ$ track floating angle



Mines' fuel quality adaptability:

4th grade fuel filter enhances the cleanliness of fuel.



-45 to +50°C large-capacity radiator + two-stage/continuous-speed fan. It matches the optimal heat dissipation performance according to the ambient temperature, optimizes energy consumption and extends the lifespan.

Convenient maintenance and servicing details

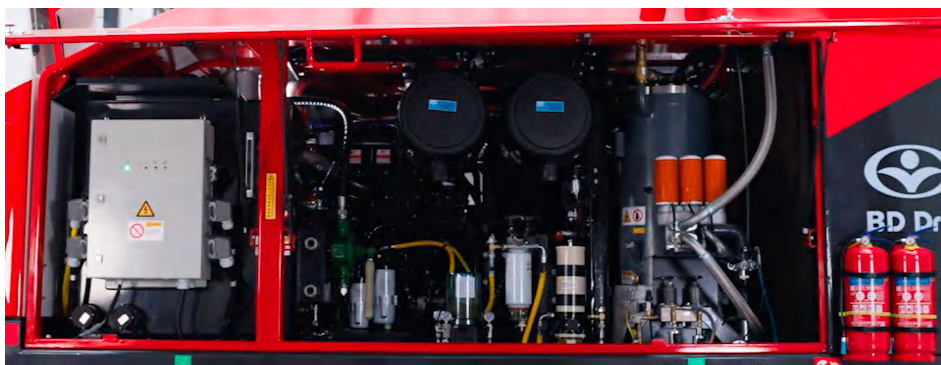

Fuel/oil filter element, air filter element, electronic control box, fuel filler opening is close to the cabin door, facilitating daily maintenance and servicing.



The centralized sewage outlet near the cabin door is convenient for changing the liquid.

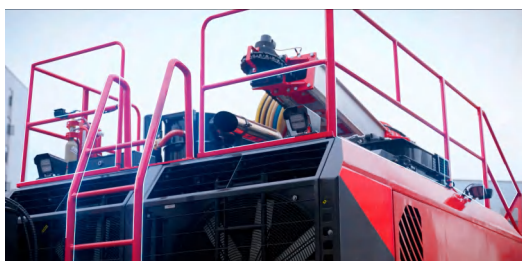

Full-enclosure guardrail at the top of the cabin and 3M anti-slip tape, enhancing maintenance safety.

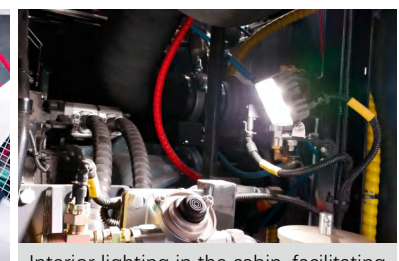
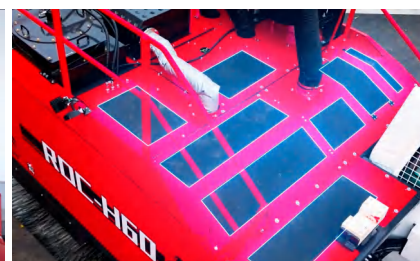

Interior lighting in the cabin, facilitating maintenance at night.



1、 Main Technical Data

Serial	Description		Unit	Parameter
1	Hole range & depth	Drilling diameter	mm	110-203
		Max hole depth	m	36
		Drilling pipes	mm	∅114(∅89/102/127/140)*6000/8000
		Numbers of pipes		5+1/4+1
		DTH hammer		4"/5"/6"
2	Engine	Model		CAT C15
		Rated power/speed	kW	403@1800rpm
		Max. Torque	N.m	2468
		Fuel tank capacity	L	1000
3	Compressor	Model		Atlas Copco two-stage screw type compressor
		FAD at normal working pressure	CFM	995
		Max. working pressure	BAR/PSI	30/435
		Compressor oil	L	70
4	Hydraulic system	Main pump Max. pull-down piston	Mpa	25
		Main pump	L/min	150+150
		Auxiliary pump	L/min	60+45+45
		Hydraulic oil tank capacity	L	400
5	Electrical system	Voltage		24V
		Batteries		4×12V, 180Ah
		Work lights, front		4×65W
		Work lights, rear		2×20W
		Work lights, feed		1×20W
		Travel lights		4×20W
		Engine room maintenance lights		2×15W
6	Dust collector	Filter area	m ²	32
		Suction capacity	m ³ /min	80
		Number of filter elements	pcs	32
7	Feed	Feed mode		Motor+ Simplex roller chain
		Travel length	mm	6580
		Length, total	mm	10630



Serial	Description		Unit	Parameter
7	Feed	Chain pitch	mm	44.45
		Tractive pull, max	kN	50
		Feed force, max	kN	40
		Feed rate, max	m/s	1.0
8	Rotary head	Torque, max	Nm	5800/6000
		Rotation speed	rpm	85/60
9	Crawler	Speed, max	km/h	3.2
		Max. climbable gradient	°	25
		Track swing Angle	°	±10
		Track width	mm	350
		Over all width	mm	2530
		Overall length	mm	3720
10	Cab	Indoor noise	dB	≤85
		Safety cabin		FOPS&ROPS
		Air-conditioning		Standard temperature
		Seat		Adjustable& Heating
11	Electrical system	Fuel tank heater		2kW/220V
		Hydraulic oil heater		2×2kW/220V
		Oil separator heater		1kW/220V
		Engine oil heating		140W/220V
		Battery heating pack		4×155W/220V
		Oil suction heating system		130W/24V
		Fuel filter heater		2×100W/24V
		Oil-water separator heater		200W/24V
		Oil filter heater		100W/24V
		Air compressor oil filter heater		3×150W/24V
		Prefilter heater		50W/24V
		Air heater starting		2.45kW/24V
		Engine coolant heater		180W
		Cab heater		90W
12	Transport dimensions (Length*Width*Height)		mm	11900*2700/3000*3580
13	Weight (standard configuration)		kg	27000

2、 Transportation & Working State

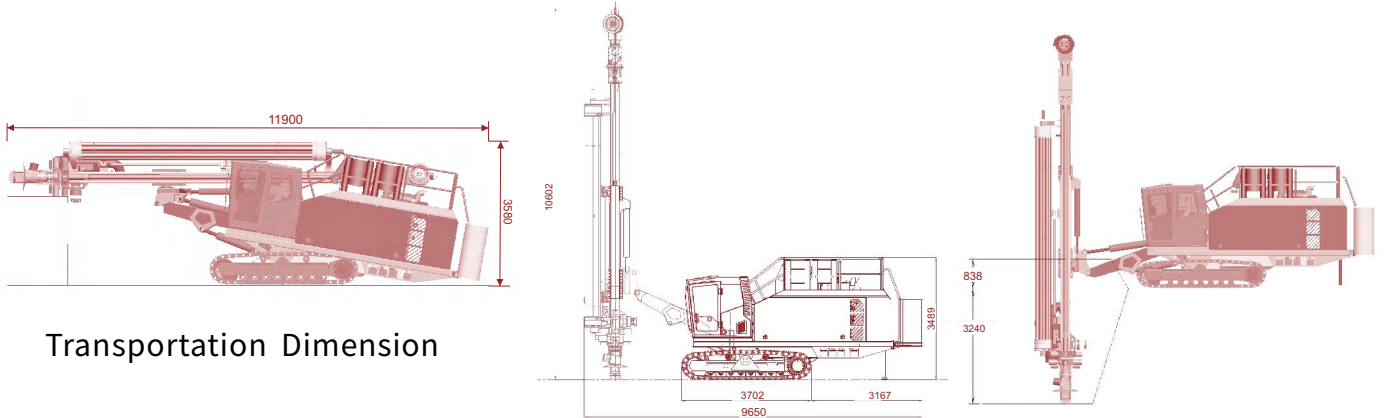

Transportation Dimension

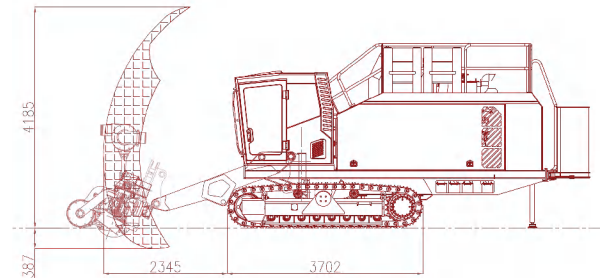
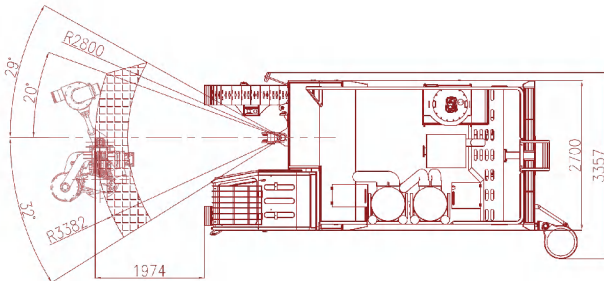

Slope gradient

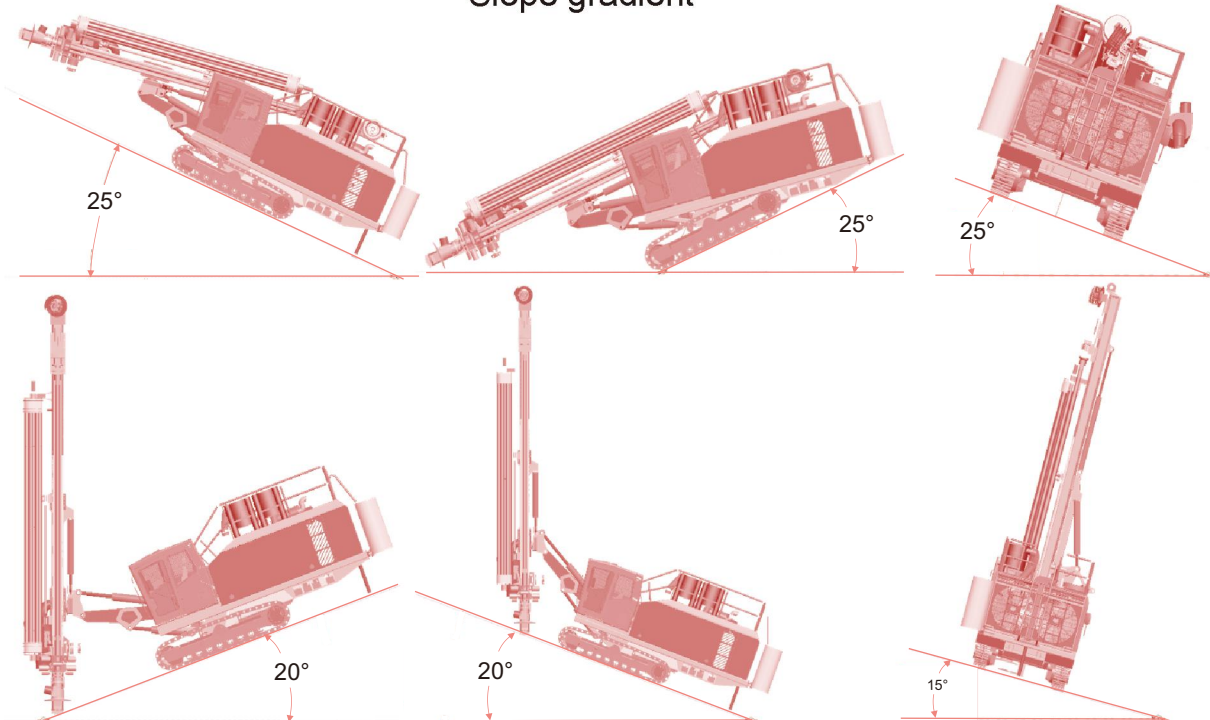

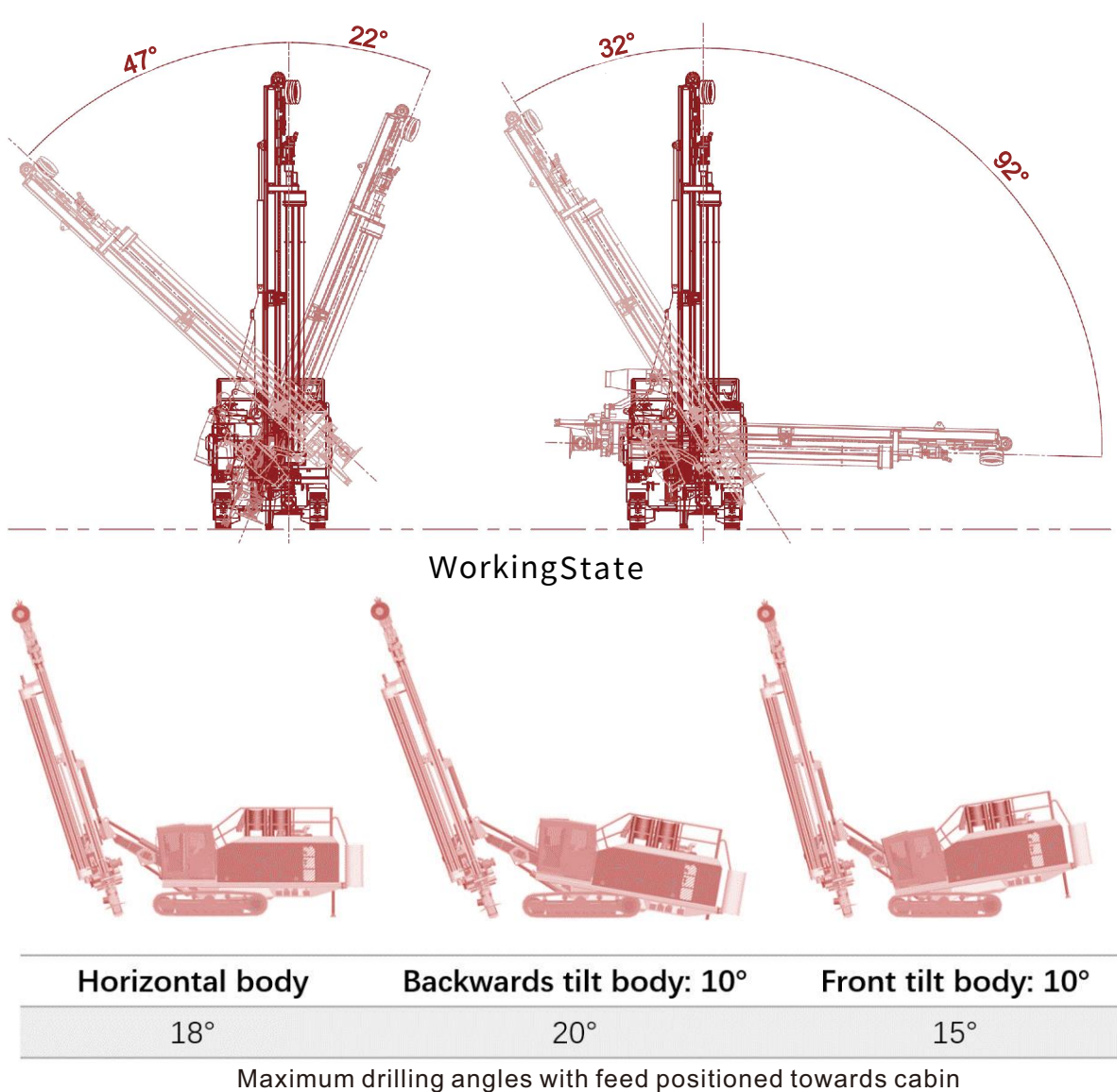

3、 Transportation plan

- Complete vehicle transportation
- Transport weight: 27000kg (excluding trailer)
- Transport width: 2700mm

4、 Driver's technical file

- Accompanied by the packing list when H60 to send, contains the following files:
- Quality certificate
- Operation and maintenance manual
- Spare parts catalogue
- Packing list (Accompanied spare details and tools List)
- Engine using and maintaining manual

Black Diamond Drilling can custom manufacture equipment to suit your drilling needs.
Please contact one of our representatives to discuss your equipment needs.



Black Diamond Drilling Services Australia Pty Ltd



WA Headquarters: 52 Distinction Road, Wangara WA 6065
Tel: +61-08-6365-6550 **Email:** sales@bdrill.com.au **Web:** www.bdrill.com.au
Kalgoorlie Branch: 2 Brooks Way, Kalgoorlie, WA, 6430
Tel: +61-08-9021-8478 **Email:** admingf@bdrill.com.au **Web:** www.bdrillgf.com.au

Black Diamond Drilling Tools Canada Inc.



Sudbury Headquarters: 1899 Lassalle Blvd, unit 6, Sudbury, On, Canada, P3A-2A3
Tel: +1-705-560-5888 **Email:** sales@bdrill.ca **Web:** www.bdrill.ca

Black Diamond Drilling Tools USA LLC.



New Hampshire Headquarters: 131 Daniel Webster Hwy, #426 Nashua, NH 03060
Tel: +1-978-319-8000 **Email:** sales@bdrill.com **Web:** www.bdrill.us

Black Diamond Mongolia Ops (TD Equipment)



Ulan Bator Headquarters: Maison Center 403, Beijing Street,
Sukhbaatar District, Ulaanbaatar, Mongolia
Tel: +976-7773-1333 **Email:** support@tdequipment.mn

Version 3.4

© Black Diamond Drilling Services Australia Pty. Ltd. 2025-7
Legal Notice: All trademarks and logos appearing in this material are owned by BDDrill Group of companies,
unless specifically indicated.