



Black Diamond Drilling offers a complete range of reverse circulation hammers along with fully integrated R.C. Bits and Shrouds that have been designed to provide a world-class sampling system. Precision engineering enables our R.C. Hammers to excel in maintaining an efficient and smooth flow of drill cuttings to the surface, ensuring cleaner, more accurate samples. This leads to more reliable data for exploration and better overall hole quality.

SPECIFICATIONS

Item	Diameter Ø	
	mm	inch
Hammer	120.5	4 3/4
Bit	124 – 152	4 7/8 - 5 3/4
Suits medium to hard ground conditions		



Top Sub Assembly

	Product Code	Description	Amt	Compatibility
A	Top Sub Assembly Remet 4"			
1	BD040-TSUB-R4	Top Sub Remet 4"	1	33-040-R40
2	BD040-SK-ASCREEEN-R4	O Ring (Adaptor Tube Remet 4")	2	38-040-001
3	BD040-ASCREEEN-R4	Adaptor Tube Remet 4"	1	20-052-R40
4	BD040-AIRSCREEN	Air Screen	1	21-040-00B
5	BD040-SK-AIRSCREEN	O Ring (Air Screen)	2	38-040-001
6	BD040-CIRCLIP	Circlip	1	41-D1400-0450
B	Top Sub Assembly Metzke 4"			
1	BD040-TSUB-M4	Top Sub Metzke 4"	1	33-040-M40
2	BD040-ASCREEEN-M4	Adaptor Tube Metzke 4"	1	20-040-M40
3	BD040-AIRSCREEN	Air Screen	1	21-040-00B
4	BD040-SK-AIRSCREEN	O Ring (Air Screen)	2	38-040-001
5	BD040-CIRCLIP	Circlip	1	41-D1400-0450
C	Top Sub Assembly Metzke 4.5"			
1	BD040-TSUB-M4.5	Top Sub Metzke 4.5"	1	33-040-M45
2	BD040-ASCREEEN-M4.5	Adaptor Tube Metzke 4.5"	1	20-040-M45
3	BD040-AIRSCREEN	Air Screen	1	21-040-00B
4	BD040-SK-AIRSCREEN	O Ring (Air Screen)	2	38-040-001
5	BD040-CIRCLIP	Circlip	1	41-D1400-0450
D	Top Sub Assembly Remet 4.5"			
1	BD040/52-SK-ASCREEEN-R4.5	O Ring (Adaptor Tube Remet 4.5")	2	41-D1400-0450
2	BD040/52-ASCREEEN-R4.5	Adaptor Tube Remet 4.5"	1	20-040-R45
3	BD040/52-CIRCLIP-1	Circlip A	1	41-D1300-0850
4	BD040/52-AIRSCREEN-R4.5	Air Screen	1	21-040-00T
5	BD040/52-CIRCLIP-2	Circlip B	1	41-D1400-0520
6	BD040-TSUB-R4.5	Top Sub Remet 4.5"	1	33-040-R45

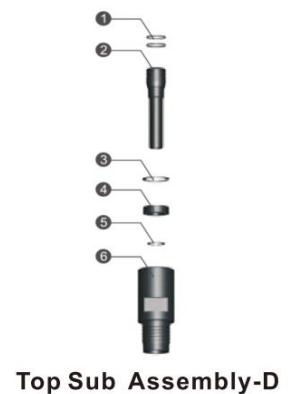
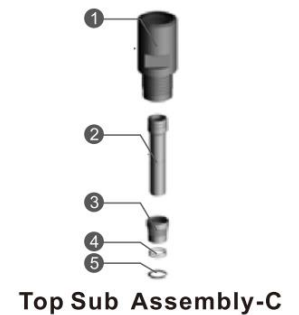
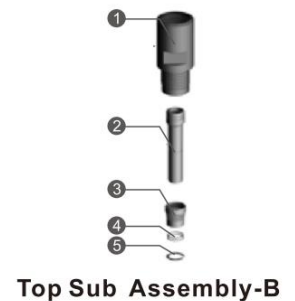
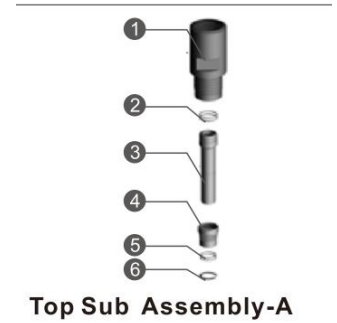

Hammer Assembly

Product Code	Description	Amt	Compatibility
7	BD040/52-CVALVE	Check Valve/Plunger	1 25-052-000
8	BD040/52-SK-CVALVE	Y Ring (Check Valve)	1 38-040-001
8	BD040/52-SPRING	Spring	1 22-040-000
10	BD040/52-SSEAT	Spring Seat	1 39-040-000
11	BD040/52-MUR-STEEL	Make Up Ring, Steel	1 24-040-000
12	BD040/52-MUR-VITON	Make Up Ring, Viton	1 28-040-000
13	BD040/52-DIST	Distributor	1 29-040-000
14	BD040/52-SK-DIST	O Ring (Distributor)	1 38-040-001
15	BD040-SK-STUBE1	O Ring (Sample Tube)	2 38-040-001
16	BD040-SK-STUBE2	O Ring (Sample Tube)	1 38-040-001
17	BD040-STUBE	Sample Tube Lower	1 37-040-000
18	BD040-STUBE-MOUNT	Mount Sample Tube	1 30-040-000
19	BD040-SK-STUBE-M	O Ring (Mount Sample Tube)	1 38-040-001
20	BD040-ICYL	Inner Cylinder	1 31-040-000
21	BD040-PISTON	Piston	1 36-040-000
22	BD040-ECYL	External Cylinder/Piston Case	1 35-040-000
23	BD040-PRING	Piston Retaining Ring	1 23-040-000
24	BD040-BUSH	Bearing Bush	1 26-040-000
25	BD040-SK-BUSH1	O Ring (Bearing Bush)	1 38-040-001
26	BD040-SK-BUSH2	O Ring (Bearing Bush)	1 38-040-001
27	BD040-SRING	Bit Stop Ring	1 27-040-000
28	BD040-SK-SRING	O Ring (Bit Stop Ring)	1 38-040-001
29	BD040-SHROUD-136/134	Shroud	1 40-040-506
30	BD040-DSUB	Drive Sub	1 16-040-000
31	BD040-135DC-TV	Drill Bit	1 63-040-506DC
32	BD040-SK	Seal Kit (Item 2+5+8+14+15+16+19+25+26+28)	1 38-040-001

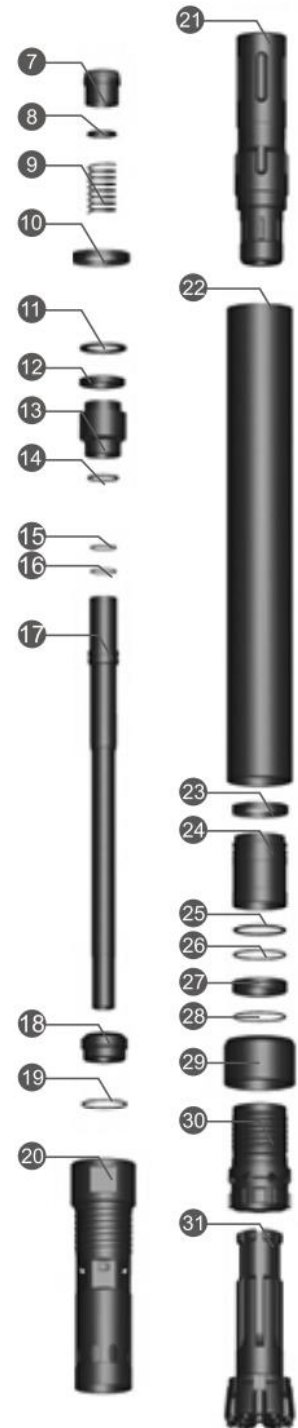

Bit Selection Table

Bit Product Code	Diameter		Compatibility
	Metric	Imperial	
BD040-124DC-TPD	124mm	4 7/8"	-
BD040-127DC-TPD	127mm	5"	63-040-502DC
BD040-133DC-TPD	133mm	5 1/4"	63-040-504DC
BD040-140DC-TPD	140mm	5 7/16"	63-040-508DC



Shroud Selection Table

Shroud Product Code	Diameter		Compatibility
	Metric	Imperial	
BD040-SHROUD-124/121.5-DB	124mm	4 7/8"	40-040-413
BD040-SHROUD-127/124.5-DB	127mm	5"	40-040-415
BD040-SHROUD-133/130.5-DB	133mm	5 1/4"	40-040-503
BD040-SHROUD-140/137.5-DB	140mm	5 1/2"	40-040-507
BD040-SHROUD-152/149.5-DB	152mm	6"	-



General Specifications

Description	Metric	Imperial
Piston Case OD	120.5mm	4 3/4"
Hammer length	1362mm	4' 5 5/8"
Hammer Weight	80.5 kg	177lb 6oz
Bit Size Range	124 -152mm	4 7/8 – 5 3/4"
Drill Rod Diameter	114mm	4 1/2"
Spanner Flat Width – Inner Cylinder	51mm	2"
Spanner Flat Width – Top Sub	51mm	2"

Air Consumption

Pressure		Consumption	
psi	bar	cfm	m ³ /min
400	27.6	850	24.0
450	31.1	925	25.1
500	34.5	1000	28.3
550	38.0	1050	29.8
600	41.4	1125	32.0

REVERSE CIRCULATION GENERAL SPECIFICATIONS

Hammer	BD351	RC3.5	BD004			BD542			BD543			BD545				BD040				BD52		BD54		A67
Top sub thread	R3"	R3"	R3.5"	R4"	M4"	R3.5"	R4"	M4"	R4"	M4"	M4.5	R4.5	M4"	R4"	M4.5"	R4.5"	m4.5"	R4.5"	M4.5"	R4.5	M4.5"			
Package case size	(L)1100 (W)110 (H)120	(L)1230 (W)120 (H)150	(L)1300 (W)150 (H)180			(L)1230 (W)140 (H)170			(L)1260 (W)150 (H)180			(L)1300 (W)150 (H)180				(L)1300 (W)160 (H)190		(L)1300 (W)160 (H)190		(L)1330 (W)160 (H)190				
Recommended bit size, mm	86-100	100-110	111-125			113-133			123-140			127-140				133-143		136-146		136-146				
Bit shank	RE531	RC3.5	RE004			RE542			RE543			RE545				RE040				PR52		PR54		BD67
External diameter, mm	81	94	107			109.5			116			117.5				121				120.5		130		132
Length excl. thread, mm (Less bit)	1069	1184	1252			1191			1261			1210				1227				1294		1200		
Hammer weight, Kg (Less bit)	29	44	52			57			63			65				53.8	47.5	69.8	69.4	68.5		84.5		81.8
Piston weight, Kg	4.8	8.3	10.5			11.6			11.6			13.5				13.6				14.3		16.8		17
Wrench flat, mm	No wrench flat	(L)82 (W)40	(L)90 (W)40	(L)90 (W)50	(L)90 (W)50	(L)95 (W)45	(L)95 (W)45	(L)95 (W)50	(L)95 (W)45	(L)95 (W)50	(L)102 (W)50	(L)102 (W)50	(L)94 (W)50	(L)94 (W)50	(L)94 (W)50	(L)94 (W)50	(L)94 (W)50	(L)94 (W)50	(L)94 (W)50	(L)100 (W)50	(L)100 (W)50	(L)95 (W)51		

Drilling conditions and project specifications may require a larger air package to be used

AIR CONSUMPTION/OPERATING PRESSURE

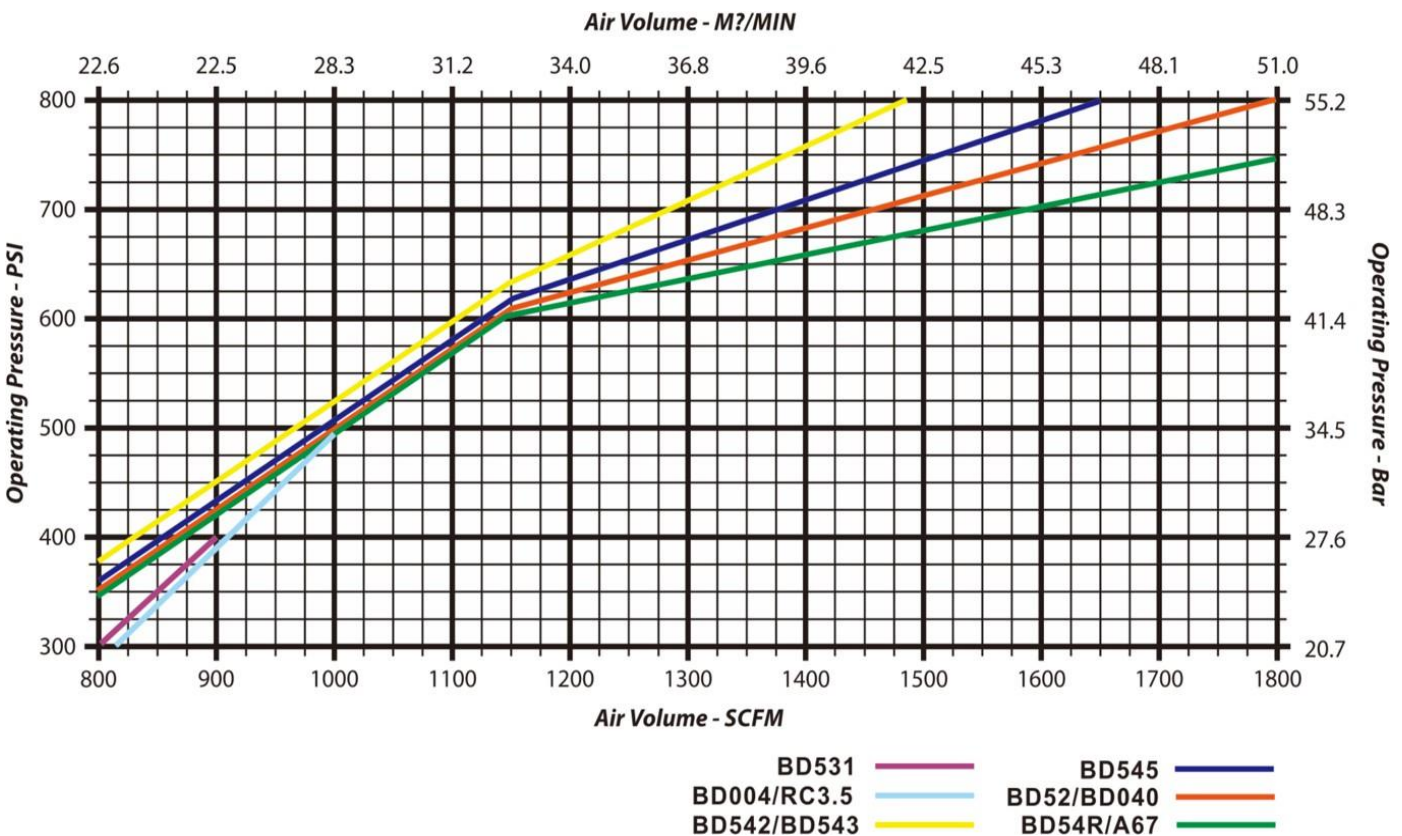

REVERSE CIRCULATION SERVICE GUIDE

When breaking a hammer down, avoid placing breakout tools in the mid-section of the cylinder (barrel). Recommended breakout points are 130mm from each end of cylinder. Wrap around chain breakouts are recommended (see diagram). When holding bits for breakout, use a secure plate or opt to grab the bit head, but never on the gauge row buttons.

This information is included with every Hammer purchase.



DO NOT APPLY HEAT OR DIRECT IMPACT TO HAMMER WHEN CRACKING JOINTS AS THIS TYPICALLY DAMAGES THE HAMMER.



Figure 1: Gripping Locations for BD DRILL Reverse Circulation Hammer

Lubrication: Correct lubrication is critical to performance and longevity.

Recommended:

- Oil Grade: SAE 320 Hammer Oil for most operating conditions
- Rate: 2 litre/hour minimum via automatic feeder
- Double the rate when injecting fluids such as water, foam & polymers
- Clean and relubricate the hammer each day after use to prevent corrosion and premature failure

