

BD531 R.C. HAMMER

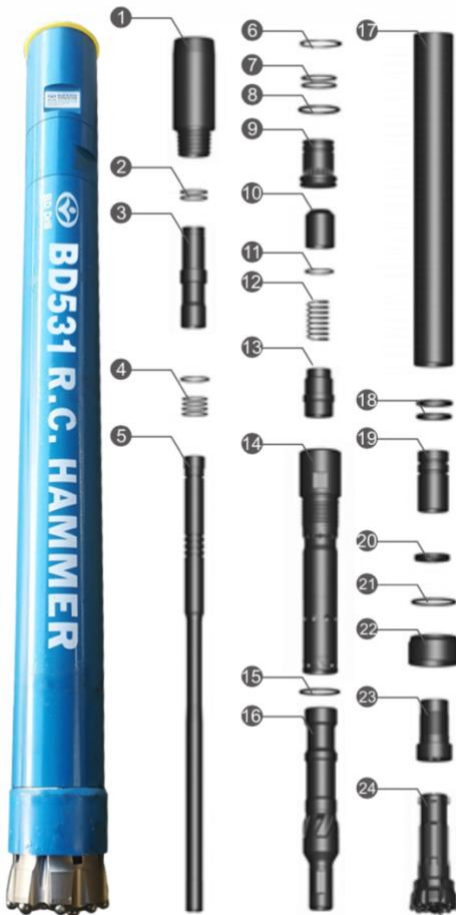

Black Diamond
Drilling Services Australia

3" R.C. Hammers	Item Description	Weight Kg	Part Number
-----------------	------------------	-----------	-------------



1	Top Sub-Remet 3"	3.76	BD531-TSUB-R3
2	O Ring (Adaptor Tube Remet 3") x 2	0.01	BD531-SK-TSUB-R3
3	Adaptor Tube Remet 3"	1.85	BD531-ASCREENR3
4	O Ring (Sample Tube) x 4	0.01	BD531-SK-STUBE
5	Sample Tube	1.97	BD531-STUBE
6	Circlip	0.04	BD531-CIRCLIP
7	O Ring (Distributor 1) x 2	0.01	BD531-SK-DIST-1
8	O Ring (Distributor 2) x 1	0.01	BD531-SK-DIST-2
9	Distributor	0.37	BD531-DIST
10	Check Valve/Plunger	0.08	BD531-CVALVE
11	O Ring (Check Valve) x 1	0.01	BD531-SK-CVALVE
12	Spring	0.1	BD531-SPRING
13	Mount Sample Tube	0.49	BD531-STUBE-MOUNT
14	Inner Cylinder/Top Barrel	3.4	BD531-ICYL
15	O Ring (Inner Cylinder) x 1	0.01	BD531-SK-ICYL
16	Piston	4.69	BD531-PISTON
17	External Cylinder/Barrel/Piston Case	9.2	BD531-ECYL
18	Seal Cover/ O Ring (Bearing Bush) x 2	0.02	BD531-SCOVER
19	Bearing Bush	1.03	BD531-BUSH
20	Bit Stop Ring	0.08	BD531-SRING
21	O Ring (Bit Stop Ring) x 1	0.01	BD531-SK-SRING
22	Shroud	0.45	BD531-SHROUD-85/83
23	Drive Sub	1.6	BD531-DSUB
24	Drill Bit	4.2	BD531-85DC-TV
25	Seal Kit (Item 2+4+7+8+11+18+21)	0.2	BD531-SK

Technical Data

Length(Less bit)	Weight(Less bit)	External Diameter	Bit Shank	Hole Range	Connection Thread
1069mm	29.0kg	Φ81mm	BD531	Φ84- Φ100	3 " Remet
Box Size	Impact rate At 2.4Mpa	Recommended rotation speed	Air Consumption		
1100x110x120mm	30Hz	25-40r/min	200-500(PSI)		
			300-1200(CFM)		